

Steam Pilot Operated PRESSURE REDUCING VALVES Class GPKP-1 Regulators

TABLE OF CONTENTS

SECTION I2
INSTALLATION2
SECTION II2
OPERATION2-3
SECTION III3
MAINTENANCE3-6
APPLICATION OF GPKP REGULATORS ON AIR/GAS SERVICE6
GPKP STEAM PILOT PRESSURE REDUCING VALVE-Capacity Regulation Curve6-7
CLASS GPKP COMPETITIVE COMPARISON7
PARTS LIST8-9
DIMENSIONS LISTING AND DRAWINGS10-11
ILLUSTRATION INDEX	
DRAWING, DIMENSIONS, TYPICAL INSTALLATIONS AND MISCELLANEOUS DATA	
Figure 1 & 2 - Recommended Valve Installation2
Figure 3 - Removing and Replacing Seat Rings4
Figure 4 - GPKP-1 Reducing Valve5

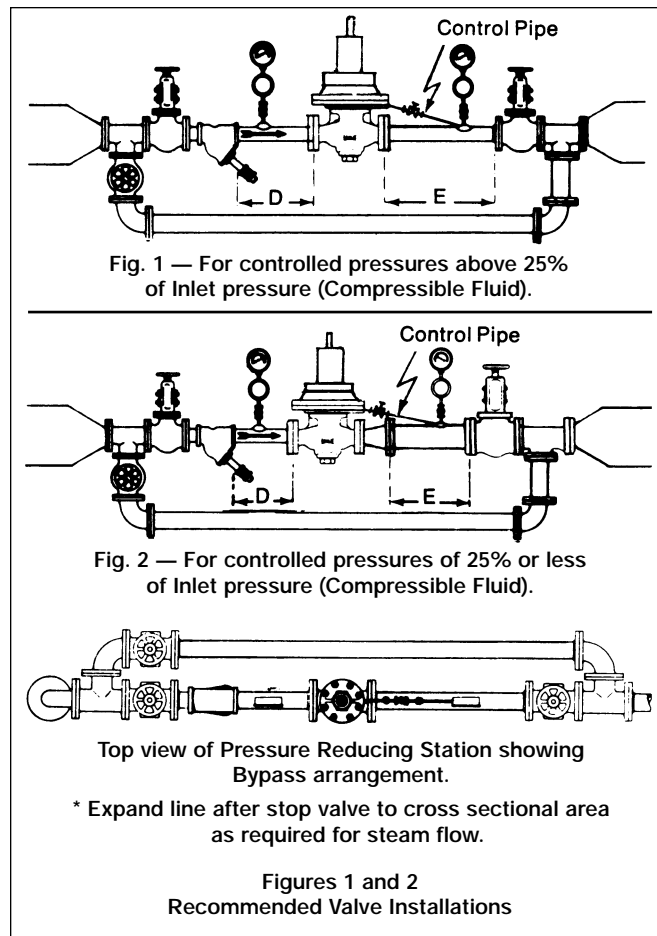

PIPING DETAILS

Recommended Straight Run Piping Dimensions inlet and outlet — All Types and Pressures

SECTION I — INSTALLATION

VALVE POSITION

Install valve upright in the highest horizontal line of piping, in an accessible location and with the arrow on the side of the body in the direction of fluid flow.

VALVE SIZE	DIMENSIONS	
	D	E
1/2" to 1-1/2"	1'6" to 5'	4' to 5'
2" to 4"	3' to 5'	4' to 8'

PROBLEM PREVENTING PROCEDURE

1. Provide space above, below and around the valve for removal of parts during maintenance.
2. Blow or flush out the pipe lines thoroughly before installing the valve.
3. Do not use red lead or cement in making up joints. In threaded valves use pipe compound sparingly on male threads only.

4. STRAINER — Protect the valve and following equipment with a Self-Cleaning Strainer.
5. Install stop valves and gages in inlet and outlet lines to provide a means for checking adjustment and operation of the equipment.
6. In steam service, insulate all piping before and after the valve to minimize condensation. Provide proper inlet drainage to prevent water hammer or erosion in the equipment.
7. Adhere to good piping practice. Install a bypass around the valve.

CONTROL PIPE — ALL PRESSURES

Connect 3/8" control pipe (having I.D. equivalent to 40 schedule pipe) with stop valve, union and pressure gage (as shown in Figures 1 and 2) from threaded connection in main body of valve to section of outlet piping before outlet stop valve. Slope control pipe downward to outlet piping to prevent water pockets. Connect control pipe to side of outlet pipe if necessary to obtain proper slope.

IMPORTANT — Make control pipe connection in expanded outlet piping at a point at a point at least 24" downstream from the end of the expander and not within 18" to 24" of the outlet stop valve, any elbow or other flow direction changing fitting. Control pipe length should be held to approximately 3'.

Recommended outlet piping for valves controlling compressible fluids at values of 25% or less of inlet pressure.

Expand outlet pipe (E dimension) to twice the valve size. Use tapered expander — 15 /20 on included angle.

NOTE: Further expansion of low pressure outlet piping beyond the outlet stop valve has no effect on operation of the valve.

SECTION II — OPERATION

OVERALL VALVE DIMENSIONS

For overall valve dimensions — face-to-face, height, etc. — consult the drawing which applies to the valve in use.

PRINCIPLE OF OPERATION

Pilot supply steam enters the pilot valve chamber and is modulated to provide a loading force on the main actuating diaphragm. The lower sensing diaphragm compares the loading pressure and downstream reduced pressures. The upper sensing diaphragm measures the downstream reduced pressure and compares it with the adjusting spring setting.

As flow demand is increased a slight drop in reduced pressure occurs. The downward force from the adjust-

ing spring defects the pilot assembly downward thus opening the pilot valve further and increases loading pressure on the main actuating diaphragm. The increased loading pressure acts on the lower sensing diaphragm in a direction opposite to the adjusting spring force. The fixed ratio of the two sensing diaphragm areas provides the precise positioning of the pilot valve and hence correct loading pressure to match system flow demand.

As flow demand decreases, the reduced pressure rises slightly. This increase causes the upward motion of the pilot assembly which closes the pilot valve. Further decreases in flow demand will result in the opening of the "bleed" port. This allows pressure on the main actuating diaphragm to exhaust to the downstream side of the valve permitting the main valve to close.

OPERATION OF GPKP-1 REDUCING VALVES

STARTING-UP:

1. Open inlet stop valve.
2. Close outlet stop valve.
3. Dispose of condensation, dirt, etc., by opening the strainer blow-off valve.
4. Crack outlet stop valve to permit slight flow when adjusting the regulating valve.
5. Slowly turn adjusting screw clockwise with a wrench until proper pilot valve setting and downstream controlled pressure is obtained.
6. Slowly open outlet stop valve.
7. To increase controlled pressure, turn adjusting screw clockwise, to decrease loading pressure turn adjusting screw counterclockwise.

SHUTTING DOWN:

To turn steam off, turn adjusting screw counterclockwise so that pilot shuts. Close inlet and outlet stop valves.

SECTION III — MAINTENANCE

Leslie control valves may be dismantled without removal from pipeline when maintenance checks are desired.

Play Safe! Use Only Genuine Leslie Replacement Parts

All Leslie controls are made of the finest material obtainable, are time-tested and backed by more than a half century of know-how. Machining is done by expert craftsman and each valve is inspected and service-tested before shipment to you.

Use of other than GENUINE LESLIE PARTS may impair their ability to serve you. DO NOT change any dimen-

sions except as noted in these instructions. To assure long life, preservation of parts interchangeability and low maintenance costs, use only standard LESLIE parts.

DISMANTLING (See Figure 3 for parts.)

1. Release all compression on adjusting spring by turning adjusting screw counterclockwise. Allow downstream steam pressure to dissipate.
2. Close Stop valve on inlet and outlet sides of the steam pilot regulating valve and crack open the strainer blow-down valve to vent trapped fluid and steam. After all pressure is relieved open blowdown valve completely.

CAUTION: Be especially careful during this procedure to avoid being scalded by steam or hot water condensate.

3. Loosen and unscrew bottom cap (28), 1/2" to 2" size, with an appropriate wrench. For the 2-1/2" to 4" size the bottom cap complete is flanged and nuts (40) and bolts (41) must be loosened and removed. The gasket (27), bushing (26), 1/2" to 2" sizes only, the valve plug spring (25) and the valve plug (22) are removed with the bottom cap.
4. Do not remove seat ring (24) unless remachining or replacement is necessary. If removal is required, see section titled REPLACED SEAT RINGS.
5. Disconnect tubing and remove adjusting spring case assembly, consisting of spring case (8), adjusting screw (1), lock nut (2), spring case cover (3), range washer (42) and cover plate (12) by removing bolts (6) holding the spring case assembly to the diaphragm cover (16).
6. Remove upper spring seat (4) and adjusting spring (5).
7. Remove subassembly consisting of upper diaphragm complete (7), diaphragm spacer (9), male elbow (23), lower diaphragm (10) and nozzle (29).
8. Remove retaining ring (11) pilot valve guide (30) and pilot valve stem.
9. Using a long 3/4" socket and socket wrench, unscrew the pilot valve seat (31). Remove the pilot ball seat (13) and pilot valve spring (34).
10. To examine diaphragm set (36), the diaphragm cover must be removed. This is accomplished as follows. Remove formed tubing assemblies (32) and (20) from diaphragm cover (16), male elbow (23) and elbow (33) using appropriate open end wrenches. Then remove elbow (33). Unscrew nuts (18) and remove bolts (15). Remove diaphragm cover (16), diaphragm set (36), consisting of two

leaves. Bottom leaf has a bleed hole in it. Then remove the diaphragm disc (17).

- Disassemble subassembly removed in step 7 by holding the stem in the upper diaphragm complete (7) with an open end wrench and removing the nozzle (29) with a 1/2 inch hex diaphragm (10) and diaphragm spacer (9).

CLEANING AND CHECKING PARTS

Clean all parts with an approved solvent. Use crocus cloth where necessary to remove encrusted matter. Check parts as shown below.

- Examine valve plug (22), seat ring (24) bushing bottom flange (26), 1/2" to 2" sizes and staked bushing in the flanged end cap assembly, 2-1/2" to 4" sizes.
- If main valve or seat ring (2-1/2" — 4" size) surfaces are scored or cut, regrind with very fine grinding compound. Remove all traces of grinding compound before reassembly. Replace bushings with new ones if required.

NOTE: FOR 2-1/2" TO 4" SIZE:

If main valve, seat ring or both must be remachined due to extensive damage to seating surfaces, it will be necessary (in order to maintain correct diaphragm disc to diaphragm seat dimension) to shorten the valve plug (22) by an amount equal to the amount of metal removed from the main valve and/or seat ring faces. This is done by removing the correct amount of metal from the top (diaphragm) end of the valve plug stem.

FOR 1/2" TO 2" SIZE.

The seat ring has a resilient seat. If the resilient seat is damaged the seat ring must be replaced. (Stellited hard faced seat is optional.)

- Clean impulse port and diaphragm seating face in the main body thoroughly.
- Check bore of main valve guide (19). Bore must be clean. Replace guide if damaged.
- Check all diaphragms for cracks and perforations. Diaphragms should be replaced if any of the above defects are found. In addition, check for surface imperfections such as deep scratches and blisters. Reject and replace diaphragms if imperfections are considered excessive.
- Check all formed tubing assemblies for cracks and deep scratches. Replaces if any of the above defects exist.
- Check pilot bail and pilot valve seat for wire drawing, scoring and radial scratches across the seat areas. The parts should be rejected if above defects are noted and replaced with new parts.

REMOVING AND REPLACING SEAT RINGS

To remove seat ring, use the special wrench which is available on request. See Fig. 3

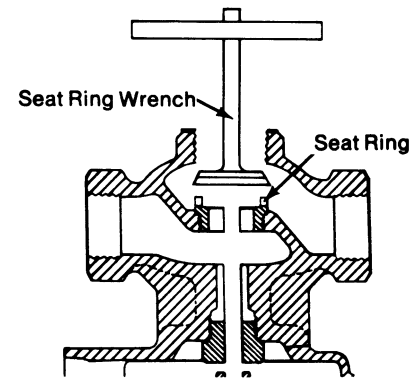

FIGURE 3

TO INSTALL SEAT RING

Position seat ring wrench and socket wrench as shown in Fig. 3. Hold tightly against seat ring. Tap handle of socket with hammer to loosen seat ring. Then unscrew seat ring.

- Carefully clean threads and joint contact surfaces on seat ring and in the valve body.
- Make sure joint surfaces are undamaged.
- Use a tight coating of Never-Seez or similar lubricant on the first two threads only of the seat ring. Screw seat ring into valve body threads and pull up tight with a wrench.
- Tap handle of socket wrench with hammer to lock seat ring in place.
- Lap in main valve and seat carefully. Use very fine lapping compound. (For metal seats only).

REASSEMBLY

- Do not use graphite or compound on joints.
- Place the bushing-bottom flange (26), 1/2" to 2" sizes only into the bottom flange (28). Install valve plug spring (25) and valve plug (22) onto bottom flange. Place gasket over bottom flange and screw bottom flange to main body with an appropriate wrench. In the 2-1/2" to 4" sizes the bottom flange is bolted to the lower flange of the valve body. Pull up bolt/nuts evenly across from each other until a tight seal is made.
- Reassemble lower diaphragm (10) onto nozzle (29). Insert upper diaphragm complete (7) into diaphragm spacer (9). After orienting spacer so that diaphragm parts of upper diaphragm complete seats on the same side as the raised center hub. Holding the stem of upper diaphragm complete (7) with an open end wrench, screw the diaphragm (10) and nozzle (29) subassembly into the threaded

SECTION III — MAINTENANCE (CONT.)

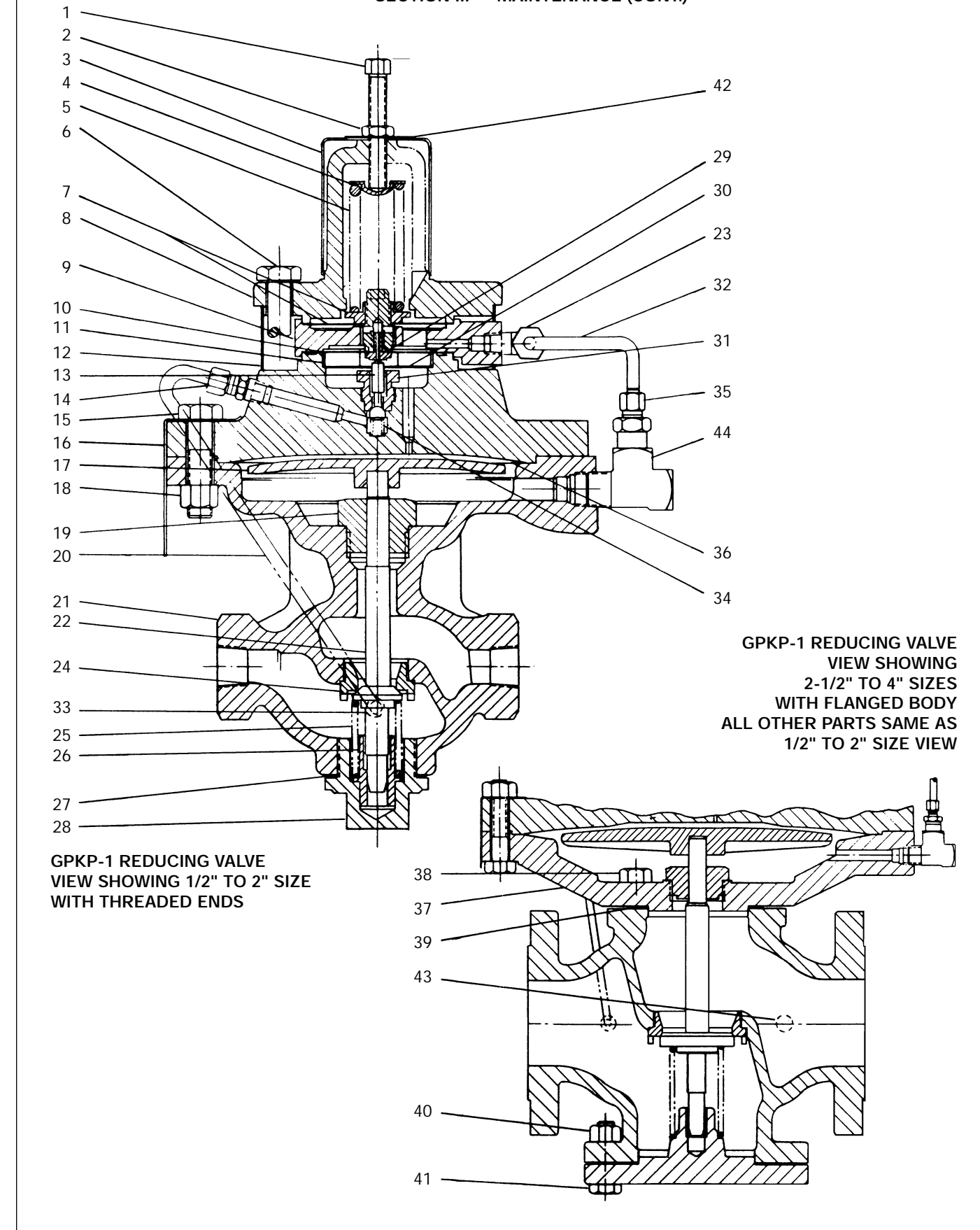

GPKP-1 REDUCING VALVE
VIEW SHOWING
2-1/2" TO 4" SIZES
WITH FLANGED BODY
ALL OTHER PARTS SAME AS
1/2" TO 2" SIZE VIEW

GPKP-1 REDUCING VALVE
VIEW SHOWING 1/2" TO 2" SIZE
WITH THREADED ENDS

FIGURE 4

female portion of the upper diaphragm complete (7) until a tight assembly of the diaphragm complete, (7) the spacer, (9) the lower diaphragm (10) and the nozzle (29) is made.

4. Install the diaphragm disc (17) onto the stem of the main valve (22). Put two diaphragm leaves together, matching convolutions as closely as possible, to form a diaphragm set (36). The bottom leaf has a bleed hole in it. The bleed hole faces the diaphragm disc (17). Place the set into the main body (20) and position them carefully above the diaphragm disc (17). Orient and position the diaphragm cover (16), and lower onto the valve body flange. Insert bolts (15) and nuts (18) and tighten sequentially and evenly across from each other until a tight diaphragm seal is achieved.
5. Install pilot valve spring (34) onto pilot of pilot ball then make sure spring is all the way to shoulder of pilot valve. There is a slight interference between pilot valve and spring. Position assembly into the diaphragm cover cavity bore. Make sure it is properly seated and moves up and down freely. Screw pilot valve seat (31) into cover (16) and tighten to 50 ft. lb.
6. Install pilot valve stem, pilot valve guide (30) and retaining ring (11), into diaphragm cover cavity. Make sure that guide (30) is not cocked or center hole edges are not damaged.
7. Orient nozzle, (29) lower diaphragm (10, spacer (9), and upper diaphragm complete assembly (7), with nozzle end pointing downward, and place onto diaphragm cover (16).
8. Place the adjusting spring (5) on the adjusting spring seat of the upper diaphragm complete (7). Install upperspring seat (4) onto spring (15). Make sure that seat hemi-head is pointing downward.
9. Orient and install adjusting spring case (8), onto upper diaphragm spacer assembly. Make sure pilot of case fits into counter bore of spacer (9) and seats against upper diaphragm. Insert bolts (6) through flange of spring case (8) and screw them into the diaphragm cover (16). Pull up bolts sequentially and evenly across from each other to 30 ft. lb. Install cover plate (12) by sliding over spring case flange.
10. Fasten formed tubing (20) to male connector (14) in street tee (16) and male elbow (23) in valve body (21). Screw on elbow (33) to nipple (35) and tighten. Make sure male connection #67205 is properly oriented to accept formed tubing (32). Attach formed tubing (32) to male elbow (23) in diaphragm spacer (9) and attach to male connection #67205 in street tee. Tighten all connectors with appropriate open end wrenches.
11. Install spring case cover (3) and range washer (42) over spring case (8) if previously removed.

12. Screw adjusting screw (1) and lock nut (2) into adjusting spring case (8) until end of adjusting screw bottoms into upper spring seat hemisphere. Tighten lock nut. Reconnect control pipe to tee in valve body flange.
13. Follow starting up procedure under section entitled "Operation of GPKP-1 Reducing Valves."

APPLICATION OF GPKP REGULATORS ON AIR/GAS SERVICE

The following guide lines apply to GPKP Regulators used on Air/Gas Service.

1. **Pressure/Temperature Limits**
 - a. Maximum inlet pressure - 250 PSIG (may be limited to a lower value by the ANSI rating for the end connections).
 - b. Maximum temperature - 450°F.
2. **Capacities**
Capacities are the same as those for the GPAK Regulators shown in Bulletin 30/4.2.2.
3. **Dead End Service**
Since these valves utilize metal seating for the pilot valve (and also for the main valve in 2½-4 inch sizes) they are not "bubble tight" on air/gas service. Maximum rated seat leakage is 0.01% of rated capacity.
4. **Hazardous Gasses**
Body joint sealing is metal-to-metal which provides tight joints on steam service. In air/gas service very slight seepage to atmosphere may occur. For this reason, GPKP Regulators are not recommended for flammable or toxic gasses.

GPKP STEAM PILOT PRESSURE REDUCING VALVE Capacity Regulation Curve

Typical problems with competitive type steam piloted regulators are the inability to maintain reduced pressure setpoint (accuracy of regulation) and a tendency to be unstable with varying pressure drop conditions.

Control Stability

The gain of the pilot on competitive units varies with over-all system pressure drop. For a given change in the outlet pressure, the pilot valve will move a fixed amount. If the pressure drop across the pilot valve is low, the pilot valve motion will create a relatively small change in loading pressure. Conversely, at high pressure drops the change in loading pressure (gain) will be proportionally greater. This increased gain at high pressure drops is what causes the instability and cycling exhibited by many competitive designs.

The new Leslie Co. GPKP steam piloted pressure reducing valve utilizes a patented dual diaphragm sensing chamber to overcome this problem. The second pilot diaphragm is used to sense the loading pressure, and for a given change in output pressure, the change in loading pressure is constant regardless of total system pressure drop. This "constant gain" feature assures maximum stability over the full operating range of the GPKP.

Accuracy of Regulation

The graph below represents the results of capacity regulation test conducted on the new GPKP and three competitive models. Each of the 2" valves tested was subjected to inlet pressure of 100 psig saturated steam. The GPKP exhibited complete stability over the full operating range. Other tests, conducted at higher and lower inlet pressures resulted in virtually the same performance characteristics.

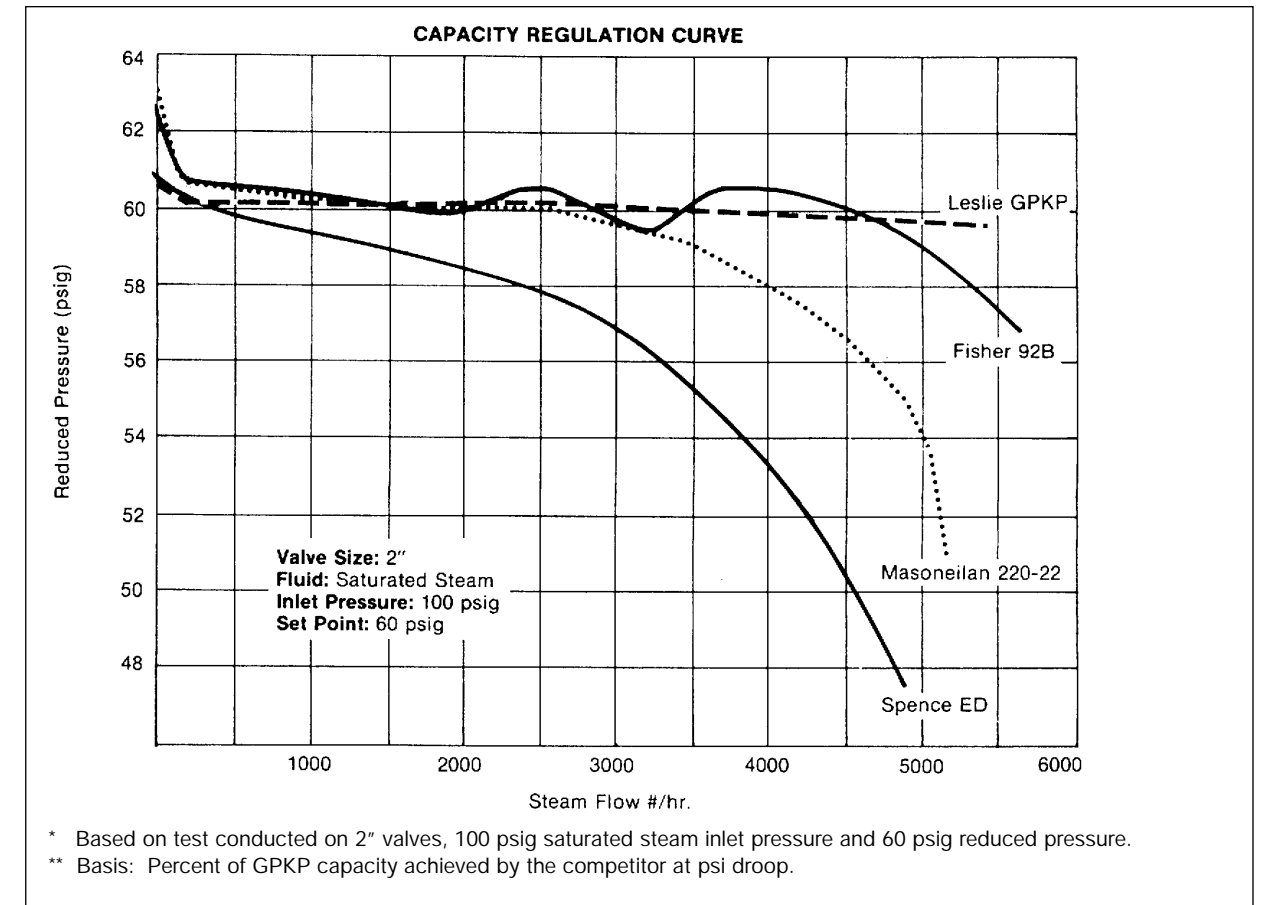

LESLIE COMPANY - CLASS GPKP - Competitive Comparison

Characteristics	Leslie GPKP	Fisher 92B	Masoneilan 220-22	Spence ED
Accuracy of Regulation*	Excellent	Good	Fair	Poor
Capacity at 1 psi droop	100%	96%**	66%**	28%**
Reduced Pressure Range	5-150 3-springs 1-Integral Pilot Assembly	2-150 6-springs 2-Pilots	2-150 3-springs 1-Pilot	3-150 4-springs 1-Pilot
Range Change: Adjusting spring case removal required	No	Yes	Yes	No (unless optional enclosed spring case purchased)
Minimum Pressure Drop across valve for full capacity	10 psi-std	20 psi-std. 10 psi-Avail. with extra cost inconel spring.	20 psi-Min. 25 psi-Recom.	10 psi-std. Lower Min. ΔP Avail. at extra cost
Pilot and Valve Fully Assembled	Yes	Yes	Yes	NO
Stability at Varying Pres. Drops	Excellent	Good	Good	Fair
Seat Ring Seat Ring Material	Hardened Stainless Steel	Hardened Stainless Steel	Stainless Steel	Brass with Stainless Steel Insert
Diaphragm	Stainless Steel with unique spiroflex design	Stainless Steel	Stainless Steel	Stainless Steel
Warranty	3 Yr.	1 Yr.	1 Yr.	1 Yr.

PART NO.	PART NAME	MATERIAL	MATERIAL SPEC.	QTY. PER UNIT	REFERENCE NUMBERS - EACH SIZE									
					1/2"	3/4"	1"	1-1/4"	1-1/2"	2"	2-1/2"	3"	4"	
1	ADJUSTING SCREW	LEDLOY 12L14	COMMERCIAL	1	66044	66044	66044	66044	66044	66044	66044	66044	66044	66044
2	LOCK NUT	STEEL	COMMERCIAL	1	49697	49697	49697	49697	49697	49697	49697	49697	49697	49697
3	SPRING CASE COVER	STEEL	COMMERCIAL	1	66045	66045	66045	66045	66045	66045	66045	66045	66045	66045
4 ★	UPPER SPRING SEAT	STEEL	COMMERCIAL	1	66039	66039	66039	66039	66039	66039	66039	66039	66039	66039
5 ★	ADJ. SPRING RANGE 5-20	MUSIC WIRE	COMMERCIAL	1	66046	66046	66046	66046	66046	66046	66046	66046	66046	66046
5 ★	ADJ. SPRING RANGE 15-75	MUSIC WIRE	COMMERCIAL	1	66047	66047	66047	66047	66047	66047	66047	66047	66047	66047
5 ★	ADJ. SPRING RANGE 50-150	MUSIC WIRE	COMMERCIAL	1	66048	66048	66048	66048	66048	66048	66048	66048	66048	66048
6	BOLT	STEEL	ASTM A-193, GR. B-7	6	10877	10877	10877	10877	10877	10877	10877	10877	10877	10877
7 *	UPPER DIAPH. COMPL. (NOTE 1)	STAINLESS STEEL	AISI TYPE 316	1	66049	66049	66049	66049	66049	66049	66049	66049	66049	66049
8	ADJUSTING SPRING CASE	CAST IRON	ASTM A-126, CL. B	1	66052	66052	66052	66052	66052	66052	66052	66052	66052	66052
9	DIAPHRAGM SPACER	CAST IRON	ASTM A-126, CL. B	1	66053	66053	66053	66053	66053	66053	66053	66053	66053	66053
10 *	LOWER DIAPHRAGM	STAINLESS STEEL	AISI TYPE 316	1	66073	66073	66073	66073	66073	66073	66073	66073	66073	66073
11 ★	RETAINING RING	STAINLESS STEEL	AISI TYPE 302	1	66054	66054	66054	66054	66054	66054	66054	66054	66054	66054
12	COVER PLATE	ALUMINUM	ASTM B-211, ALLOY 2017/2024	1	67455	67455	67455	67455	67455	67455	67455	67455	67455	67455
13 ★	PILOT VALVE COMPLETE	(NOTE 8)	(NOTE 8)	1	66056	66056	66056	66056	66056	66056	66056	66056	66056	66056
14	MALE CONN. (1/8" NPT)	BRASS	COMMERCIAL	1	67204	67204	67204	67204	67204	67204	67204	67204	67204	67204
15	BOLT	STEEL	SAE GR. 5	(NOTE 3)	33824	33824	33824	53578	53578	53578	58741	58741	58741	58741
15	BOLT	STEEL	ASTM A-193, GR. B-7	(NOTE 4)	-	-	-	9008	9008	9008	11886	11886	11886	11886
16	DIAPHRAGM COVER	CAST IRON	ASTM A-126, CL. B	1	67427	67427	67427	67426	67426	67426	67442	67442	67442	67442
17	DIAPHRAGM DISC.	(NOTE 7)	(NOTE 7)	1	33715	33715	33715	33663	33663	33663	36138	36138	36138	36138
18	NUT	STEEL	COMMERCIAL	(NOTE 3)	33816	33816	33816	33816	33816	33816	36147	36147	36147	36147
19 ★	MAIN VALVE GUIDE	BRONZE	B-124, ALLOY 3	1	41294	41294	41294	41294	41294	41294	36145	36145	36145	36145
20	TUBING (1/4")	COPPER	ASTM B-75	1	67841	67341	67841	67842	67842	67842	67843	67843	67843	67843
21	BODY THREADED	CAST IRON	ASTM A-126, CL. B	1	67443	67444	67445	67446	67447	67448	-	-	-	-
21	BODY 125# FLG.	CAST IRON	ASTM A-126, CL. B	1	-	-	-	-	-	67450	44745	44745	44745	44745
21	BODY 250# FLG.	CAST IRON	ASTM A-126, CL. B	1	-	-	-	-	67449	67451	44744	44755	44766	44766
22	VALVE PLUG	SST 17-4 PH	ASTM A-564, TYPE 630	1	59281	59283	59279	59276	59265	59265	59267	59257	59274	59274
23	UPPER ELBOW (1/8" NPT)	BRASS	COMMERCIAL	1	67203	67203	67203	67203	67203	67203	67203	67203	67203	67203
24 ★	SEAT RING	(NOTE 5)	(NOTE 5)	1	60401	60402	60403	60404	60405	60405	66089	66090	66091	66091
25 ★	VALVE PLUG SPRING	STAINLESS STEEL	AISI TYPE 302	1	48035	48035	48036	48036	48037	48037	48038	48038	48039	48039
26	BUSHING, BOTTOM FLANGE	BRONZE	ASTM B-124, ALLOY 464	1	56934	56934	56936	55880	56943	56943	-	-	-	-
27	GASKET, BOTTOM FLANGE	COPPER	ASTM B-152	1	28138	28138	28139	28140	16511	16511	4965467	4965567	4965667	4965667
28	BOTTOM FLANGE	CAST IRON	ASTM A-126, CL. B	1	55883	55883	56061	56062	56189	56189	36310	36140	37061	37061
29 ★	NOZZLE	STAINLESS STEEL	AISI TYPE 303	1	66057	66057	66057	66057	66057	66057	66057	66057	66057	66057
30 ★	PILOT VALVE GUIDE	STAINLESS STEEL	AISI TYPE 302	1	66040	66040	66040	66040	66040	66040	66040	66040	66040	66040
31 ★	PILOT VALVE SEAT	SST 440C	COMMERCIAL	1	66058	66058	66058	66058	66058	66058	66058	66058	66058	66058
32	TUBING (1/4")	COPPER	ASTM B-75	1	67844	67844	67844	67845	67845	67845	67846	67847	67848	67848
33	LOWER ELBOW (1/8" NPT)	BRASS	COMMERCIAL	1	67203	67203	67203	67203	67203	67203	67206	67206	67206	67206
34 ★	PILOT VALVE SPRING	STAINLESS STEEL	AISI TYPE 302	1	66059	66059	66059	66059	66059	66059	66059	66059	66059	66059
35	MALE CONN. (3/8" NPT)	BRASS	COMMERCIAL	1	67205	67205	67205	67205	67205	67205	67205	67205	67205	67205
36	DIAPHRAGM SET (NOTE 2)	STAINLESS STEEL	AISI TYPE 316	1	55062	55062	55062	55063	55063	55063	55064	55064	55064	55064
37 *	DIAPHRAGM BASE	CAST IRON	ASTM A-126, CL. B	1	-	-	-	-	-	-	67452	67428	67454	67454
38	BOLT	STEEL	ASTM A-193, GR. B-7	(NOTE 6)	-	-	-	-	-	-	4021	11886	11886	11886
39	GASKET, DIAPHRAGM BASE	ARMSTRONG, AN 890	COMMERCIAL	1	-	-	-	-	-	-	1852467	1852567	1852667	1852667
40	NUT	STEEL	ASTM A-194, GR. 2H	8	-	-	-	-	-	-	3676	3677	3678	3678
41	BOLT	STEEL	ASTM A-193, GR. B-7	8	-	-	-	-	-	-	33754	36150	12984	12984
42	RANGE WASHER, RANGE 5-20	ALUMINUM	ASTM B-211, ALLOY 2017/2024	1	66041	66041	66041	66041	66041	66041	66041	66041	66041	66041
42	RANGE WASHER, RANGE 15-75	ALUMINUM	ASTM B-211, ALLOY 2017/2024	1	66042	66042	66042	66042	66042	66042	66042	66042	66042	66042
42	RANGE WASHER, RANGE 50-150	ALUMINUM	ASTM B-211, ALLOY 2017/2024	1	66043	66043	66043	66043	66043	66043	66043	66043	66043	66043
43	PIPE PLUG	CAST IRON, SQ. HEAD	ASTM A-126, CL. B	1	-	-	-	-	-	-	10514	10514	10514	10514
44	STREET TEE	BRASS	COMMERCIAL	1	67202	67202	67202	67202	67202	67202	67202	67202	67202	67202

* Recommended Spare Parts

★ These parts should be on hand, plus recommended spare parts, when overhauling this equipment.

NOTE 1 - Upper diaphragm complete consists of adjusting spring seat, diaphragm and diaphragm stem.

NOTE 2 - Two (2) leaves, bottom leaf has bleed hole.

NOTE 3 - Quantities are twelve (12) for the 1/2", 3/4", 1" and 2" sizes.

NOTE 4 - Quantities are two (2) for all sizes, except four (4) for the 2" size.

NOTE 5 - Seat rings for 1/2" to 2" sizes are stainless steel, AISI Type 416 with resilient seat and SST 17-4 PH. COND A, ASTM A-564 Type 630 for 2-1/2" and 4" sizes.

NOTE 6 - Quantities are eight (8) for the 2-1/2" and 4" sizes and six (6) for the 3" size.

NOTE 7 - Material for 1/2" to 2" sizes is carbon steel, Commercial, and 2-1/2" to 4" sizes are cast iron, ASTM A-126, CL. B.

NOTE 8 - Pilot Valve complete consists of Pilot Valve Stem, SST 17-4 PH COND. A, ASTM A-564 Type 630 and Pilot Valve, SST 440C, Commercial

DIMENSIONS IN INCHES AND MILLIMETERS

NOM. PIPE SIZE	A	B	C	C-D	D	E	F	G	H	J	K	BOLT HOLE	NO. OF HOLES	BOLT SIZE	NET WT. *
THREADED															
1/2 in 15 mm	6-1/8 155.6	13-5/8 346.1	2-1/4 57.2	6-3/8 161.9	- -	- -	- -	- -	- -	8-5/8 219.1	3-5/8 92.1	- -	- -	- -	45 lb. 20.4 kg.
3/4 in 20 mm	6-1/2 165.1	13-5/8 346.1	2-1/4 57.2	6-3/8 161.9	- -	- -	- -	- -	- -	8-5/8 219.1	3-5/8 92.1	- -	- -	- -	48 lb. 21.8 kg.
1 in 25 mm	7-1/4 184.2	13-3/4 349.3	2-1/4 57.2	6-3/8 161.9	- -	- -	- -	- -	- -	8-5/8 219.1	4 101.6	- -	- -	- -	54 lb. 24.5 kg.
1-1/4 in 32 mm	7-5/8 193.7	14 355.6	2-11/16 68.3	6-3/4 171.5	- -	- -	- -	- -	- -	10-1/4 260.4	4-1/4 108.0	- -	- -	- -	67 lb. 30.4 kg.
1-1/2 in 40 mm	8-1/2 215.9	14-1/4 362.0	2-15/16 74.6	7-3/4 196.9	- -	- -	- -	- -	- -	10-1/4 260.4	4-3/8 111.1	- -	- -	- -	68 lb. 30.8 kg.
2 in 50 mm	8-1/2 215.9	14-5/16 363.5	3 76.2	7-3/4 196.9	- -	- -	- -	- -	- -	10-1/4 260.4	4-3/8 111.1	- -	- -	- -	68 lb. 30.8 kg.
125 LB. ANSI FLANGE															
2 in 50 mm	10 254	14-15/16 363.5	3-1/4 82.6	7-3/4 196.9	6 152.4	5/8 15.9	- -	4-3/4 120.7	- -	10-1/4 260.4	4-3/8 111.1	3/4 19.1	4 101.6	5/8 15.9	82 lb. 37.2 kg.
2-1/2 in 65 mm	10-7/8 276.2	15-3/4 400.1	5-1/2 139.7	7-1/8 181.0	7 177.8	11/16 17.5	- -	5-1/2 139.7	- -	16 406.4	5-3/8 136.5	3/4 19.1	4 101.6	5/8 15.9	204 lb. 92.5 kg.
3 in 80 mm	11-3/4 298.5	16-1/2 419.1	6-1/4 158.8	8 203.2	7-1/2 190.5	3/4 19.1	- -	6 152.4	- -	16 406.4	6-3/16 157.2	3/4 19.1	4 101.6	5/8 15.9	232 lb. 106.2 kg.
250 LB. ANSI FLANGE															
4 in 100 mm	13-7/8 352.4	17-7/8 454.0	7-5/16 185.7	8-1/4 209.6	9 228.6	15/16 23.8	- -	7-1/2 190.5	- -	16 406.4	7 1/2 190.5	3/4 19.1	8 203.2	5/8 15.9	259 lb. 117.5 kg.
1-1/2 in 40 mm	10-1/2 266.7	14-1/4 362.0	3-1/4 82.6	7-3/4 196.9	6-1/8 155.6	3/4 19.1	3-9/16 90.5	4-1/2 114.3	1/16 1.6	10-1/4 260.4	4-3/8 111.1	7/8 22.2	4 101.6	3/4 19.1	82 lb. 37.2 kg.
2 in 50 mm	10-1/2 266.7	14-5/16 363.5	3-1/4 82.6	7-3/4 196.9	6-1/2 165.1	13/16 20.6	4-3/16 106.4	5 127	1/16 1.6	10-1/4 260.4	4-3/8 111.1	3/4 19.1	8 203.2	5/8 19.1	82 lb. 37.2 kg.
2-1/2 in 65 mm	11-1/2 292.1	15-3/4 400.1	5-1/2 139.7	7-7/8 200.0	7-1/2 190.5	15/16 23.8	4-15/16 125.4	5-7/8 149.2	1/16 1.6	16 406.4	5-3/8 136.5	7/8 22.2	8 203.2	3/4 19.1	209 lb. 94.8 kg.
3 in 80 mm	12-1/2 317.5	16-1/2 419.1	6-1/4 158.8	8 203.2	8-1/4 209.6	1-11/16 27	5-11/16 144.5	6-5/8 168.3	1/16 1.6	16 406.4	6-3/16 157.2	7/8 22.2	8 203.2	3/4 19.1	242 lb. 109.8 kg.
4 in 100 mm	14-1/2 368.3	17-7/8 454.0	7-5/16 185.7	8-1/4 209.6	10 254	1-3/16 30.2	6-15/16 176.2	7-7/8 200.0	1/16 1.6	16 406.4	7-1/2 190.5	7/8 22.2	8 203.2	3/4 19.1	292 lb. 132.4 kg.

* APPROXIMATE

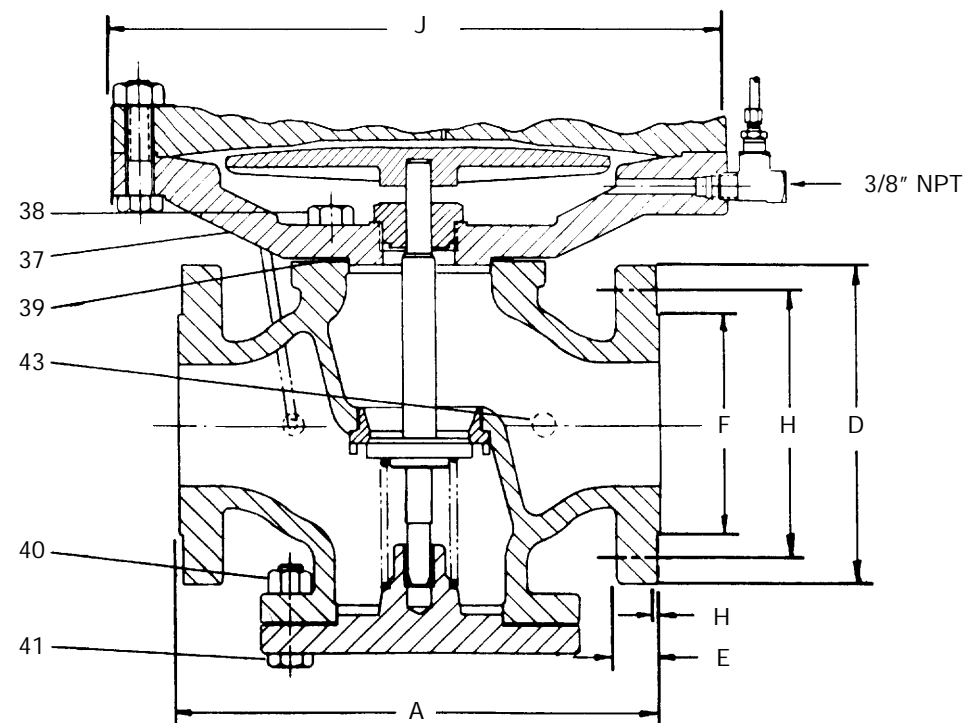

VIEW SHOWING 2-1/2" TO 4" SIZES WITH FLANGED BODY ALL OTHER PARTS SAME AS 1/2" TO 2" SIZE VIEW

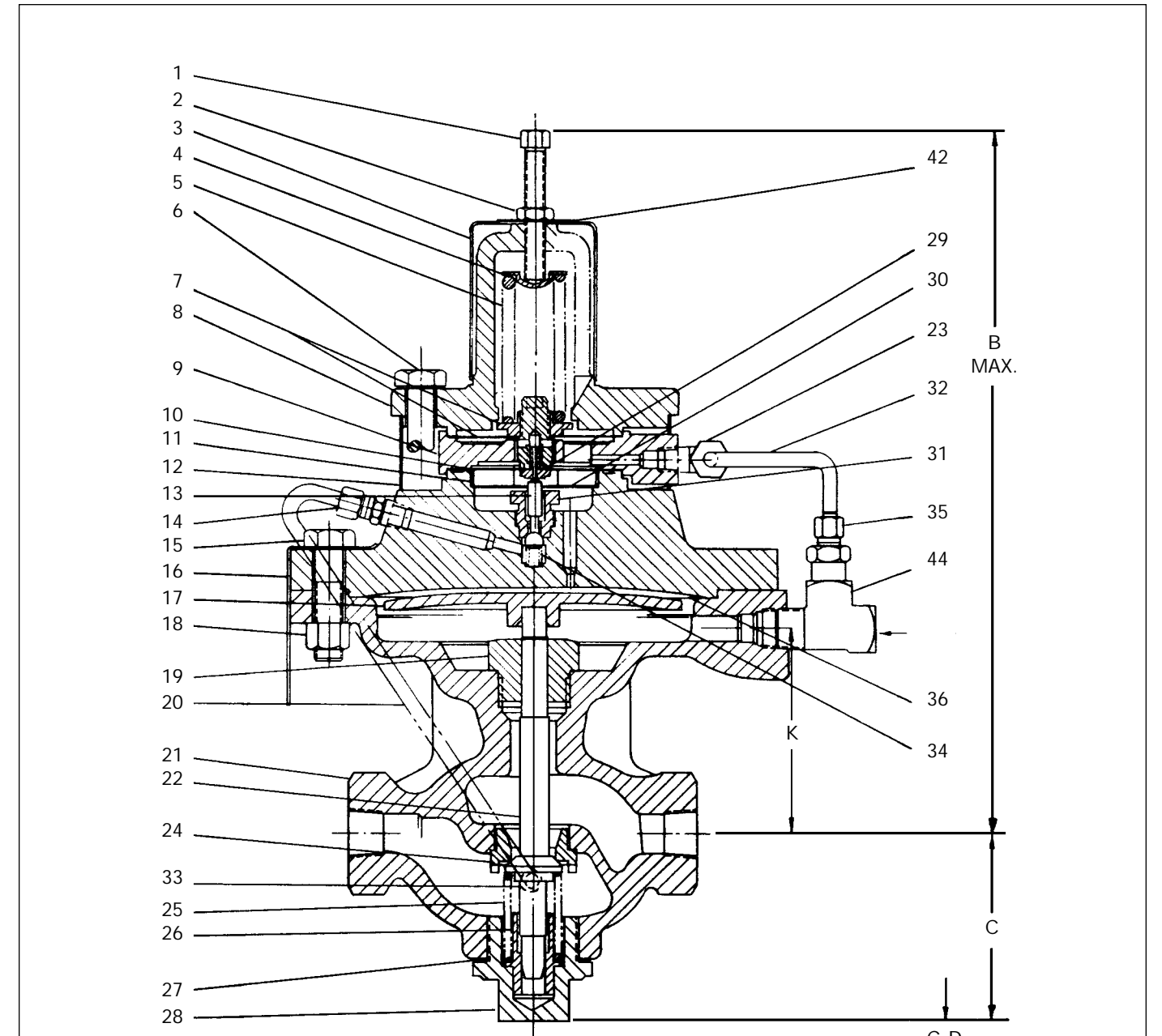

VIEW SHOWING 1/2" TO 2" SIZES WITH THREADED ENDS

U.S. PATENT 4,250,913

LESLIE 12501 Telecom Drive
CONTROLS, INC. TAMPA, FLORIDA 33637
 A division of CIRCOR International, Inc. (813) 978-1000

1/2 — 4" STEAM PILOT OPERATED PRESSURE REDUCING VALVE CLASS GPKP-1
 125 #, 250 #, FLANGE AND THREADED

DATE	APP'D.	D'W'N'	DWG. NO.	30/6.4.1 Rev.4
1/20/83	JR	BW		

PRINTED IN USA 1194 4.37C



A division of CIRCOR International, Inc.

12501 Telecom Drive • Tampa, FL 33637
(813) 978-1000 • FAX: (813)-978-0984